

9.5-hp engines (CH395)

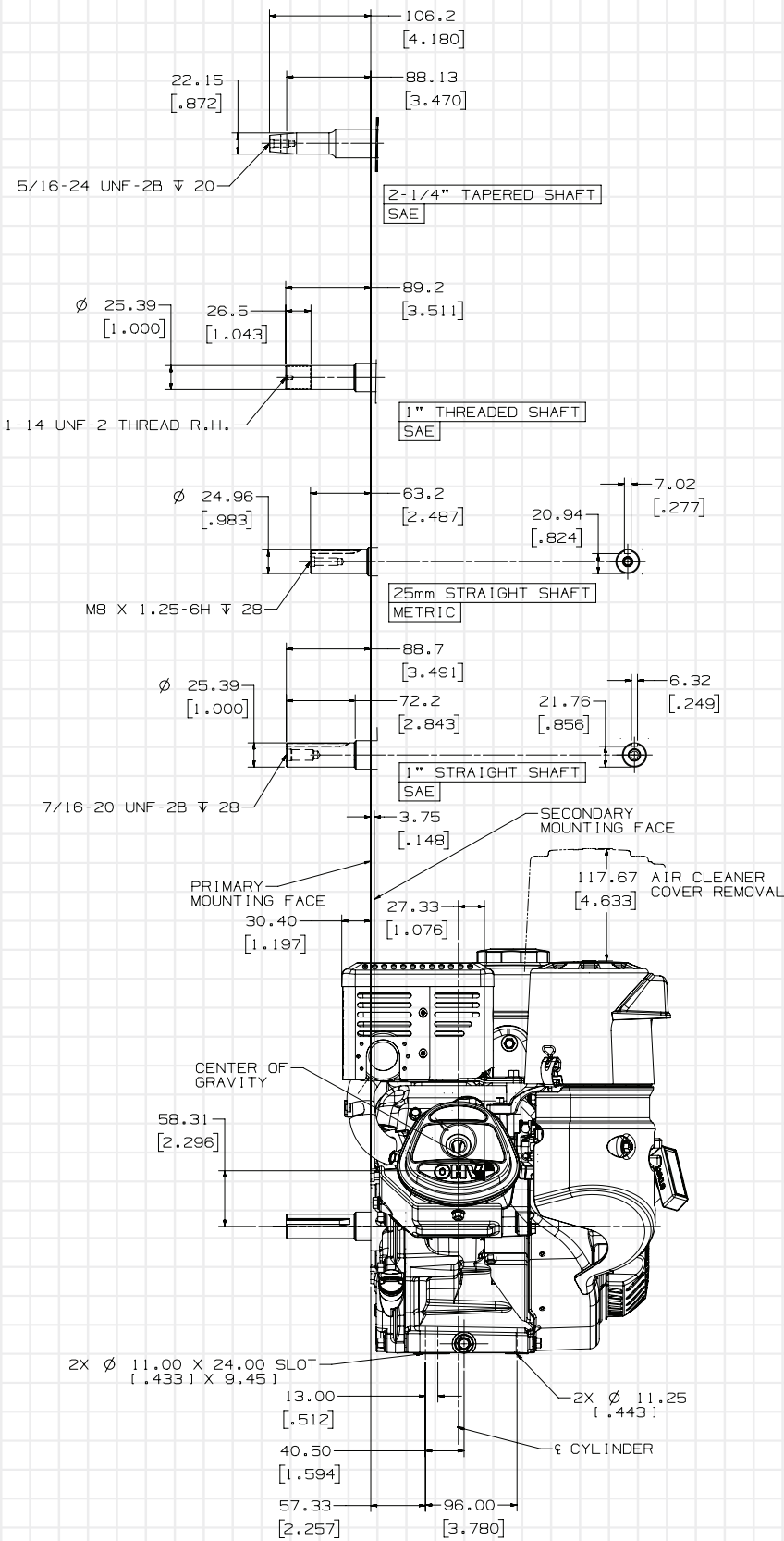

SHAFT VARIATIONS

VALVE COVER VIEW

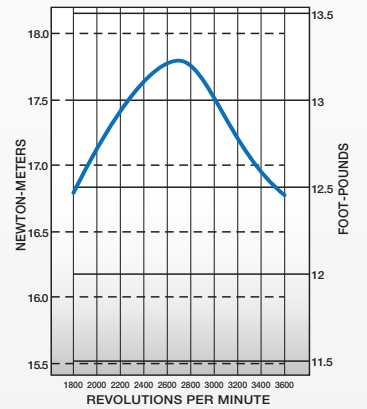
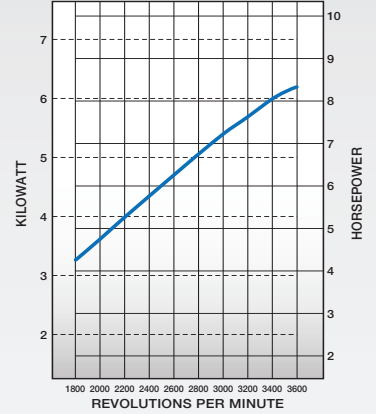

Net Torque