

KOHLER®

IN POWER. SINCE 1920.

Doc. #

320158_0_02

PAGE 1 | 4

IT	CIRCOLARE TECNICA	Gruppo Motore		Modello		A partire da S/N	
EN	SERVICE LETTER	Engine Group		Model		From S/N	KDW702 4919300540
FR	CIRCULAIRE TECHNIQUE	Groupe Moteurs	32	Modèle	KDW702 KDW1003 KDW1404	À partir de S/N	KDW1003 5006502330
ES	CIRCULAR TÉCNICA	Grupo Motores		Modelo		A partir de S/N	KDW1404 4924102240
DE	TECHNISCHES RUNDSHREIBEN	Motorgruppe		Modell		Ab Seriennummer	

IT	OGGETTO	Modifica basamenti serie FOCS e cuscinetti di banco
EN	OBJECT	Change to FOCS series crankcases and main bearings
FR	OBJET	Modification des carters série FOCS et des paliers de vilebrequin
ES	ASUNTO	Modificación cajas del cigüeñal serie FOCS y cojinetes principales
DE	GEGENSTAND	Änderung der Kurbelgehäuse der Serie FOCS und der Hauptlager

IT La presente circolare tecnica annulla e sostituisce la precedente:
 EN This service letter cancels and replaces the previous one:
 FR Cette circulaire technique annule et remplace la précédente: Doc. # 320158_0_01
 ES La presente circular técnica anula y sustituye la anterior:
 DE Das vorliegende Technisches Rundschreiben ersetzt das vorige mit dem:

- IT - Le informazioni contenute nel presente documento sono di proprietà esclusiva della LOMBARDINI srl, pertanto non sono permesse riproduzioni o ristampe né parziali né totali senza il permesso espresso della LOMBARDINI srl.
- EN - The information contained within this document is the sole property of LOMBARDINI srl. As such, no reproduction or replication in whole or part is allowed without the express written permission of LOMBARDINI srl.
- FR - Les informations contenues dans ce document sont la propriété exclusive de Lombardini Srl. Par conséquent, la reproduction ou la duplication en tout ou partie, ne sont pas autorisés sans une autorisation écrite de Lombardini Srl.
- ES - Las informaciones contenidas en el presente documento son de propiedad exclusiva de Lombardini SRL, por tanto no está permitida su reproducción o su copia impresa parcial ni total sin el consentimiento expreso de Lombardini SRL.
- DE - Alle Angaben und Informationen in diesem Dokument sind Eigentum der Lombardini srl. Jegliche Form der Vervielfältigung oder Wiedergabe bedarf der vorherigen schriftlichen Genehmigung durch Lombardini srl.

	Filed by	Viewed / Approved	DATE (MMDDIYYYY)	MAT
	<i>Accoti CC</i>	<i>J/A Durb</i>	0312712020	56730

IT	Descrizione	<p>I nuovi basamenti differiscono per le seguenti modifiche:</p> <ul style="list-style-type: none"> - sistema di centraggio tramite 2 bussole dei supporti di banco (vedere Pos. 020 2 che diventa 020 10) - spostamento delle tacche di posizione dei semicuscinetti di banco (vedere Pos. 020 6 > rif. A) <p>Vengono rilasciati i nuovi codici a ricambio coinvolti dalla modifica qui di seguito elencati:</p> <ul style="list-style-type: none"> - Cuscinetti di banco STD - Cuscinetti di banco -0.25mm - Cuscinetti di banco -0.5mm - Albero a gomito completo di cuscinetti di banco - Basamento completo di supporti
EN	Description	<p>The new crankcases differ from the previous ones due the following changes:</p> <ul style="list-style-type: none"> - centring system through 2 bushings of the main bearings (see Pos. 020 2 that becomes 020 10) - movement of position notches of crankshaft half-bearings (see Pos. 020 6 > ref. A) <p>The new spare part numbers involved in the change have been released and are listed here below:</p> <ul style="list-style-type: none"> - STD main bearings - -0.25mm main bearings - -0.5mm Main bearings - Crankshaft complete with main bearings - Crankcase complete with main bearings
FR	Description	<p>Les nouveaux carters se distinguent par les modifications suivantes :</p> <ul style="list-style-type: none"> - système de centrage au moyen de 2 clés à douille des supports de vilebrequin (voir la Pos. 020 2 modifiée en 020 10) - déplacement des crans de position des demi-coussinets de vilebrequin (voir la Pos. 020 6 > réf. A) <p>On fournit les nouveaux codes pièces de rechange concernés par la modification comme listé ci-dessous :</p> <ul style="list-style-type: none"> - Paliers de vilebrequin STD - Paliers de vilebrequin -0,25mm - Paliers de vilebrequin -0,5mm - Vilebrequin complet de paliers de vilebrequin - Carter complet de supports
ES	Descripción	<p>Las nuevas cajas del cigüeñal se diferencian por las siguientes modificaciones:</p> <ul style="list-style-type: none"> - sistema de centrado mediante 2 casquillos de los soportes del cigüeñal (ver Pos. 020 2 que se modifica en 020 10) - desplazamiento de las muescas de posición de los semi-cojinetes del cigüeñal (ver Pos. 020 6 > ref. A) <p>Se han creado nuevos códigos para los recambios modificados, que se indican a continuación:</p> <ul style="list-style-type: none"> - cojinetes principales STD - cojinetes principales -0,25 mm - cojinetes principales -0,5 mm - cigüeñal con cojinetes principales - caja del cigüeñal con soportes
DE	Beschreibung	<p>Die neuen Kurbelgehäuse unterscheiden sich aufgrund der folgenden Änderungen:</p> <ul style="list-style-type: none"> - Zentriersystem mittels 2 Buchsen der Kurbelgehäuselagerungen (siehe Pos. 020 2, die zu 020 10 wird) - Versatz der Positionsmarkierungen der Kurbelwellenlagerhälften (siehe Pos. 020 6 > Bez. A) <p>Die neuen, von der Änderung betroffenen Ersatzteilnummern lauten wie folgt:</p> <ul style="list-style-type: none"> - STD-Hauptlager - Hauptlager -0,25 mm - Hauptlager -0,5 mm - Kurbelwelle komplett mit Hauptlagern - Kurbelgehäuse komplett mit Lagerungen

	Condition						
	+	-	D	<	E	I	N
IT	nuovo	eliminato	non più disponibile	montato fino a S/N	in esaurimento	intercambiabile	non intercambiabile
EN	New	Eliminated	No longer available	Assembled to S/N	Till stock lasts	Interchangeable	Not interchangeable
FR	Nouveau	Éliminé	Pas disponible	Monté jusqu'à S/N	En cours d'épuisement	Interchangeable	Pas interchangeable
ES	Nuevo	Eliminado	Ya no está disponible	Montado hasta S/N	Pocas existencias	Intercambiable	No intercambiable
DE	Neu	Entfallen	Nicht mehr erhältlich	Montiert bis Seriennr	Nur noch wenige Stücke vorrätig	Austauschbar	Nicht austauschbar

Prima Before Avant Antes Vorher Dopo After Après Después Nachher

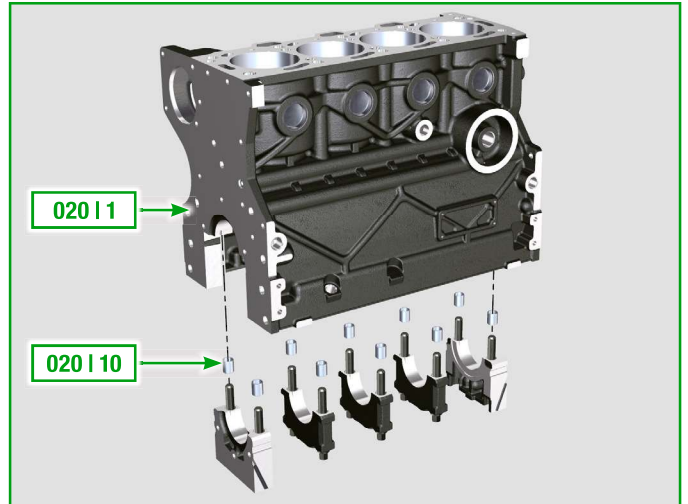
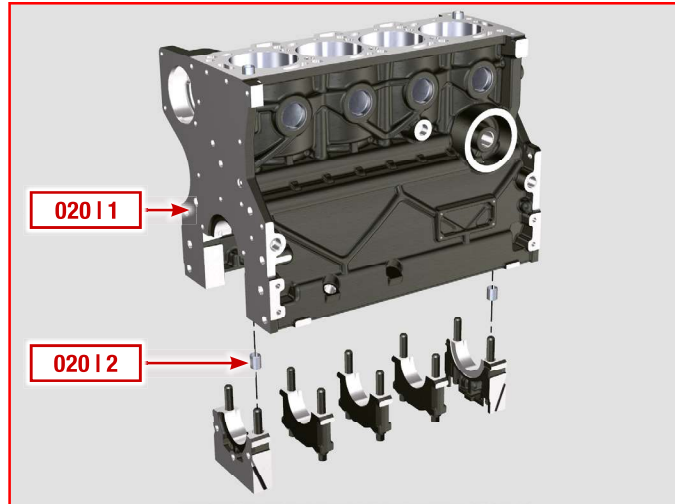
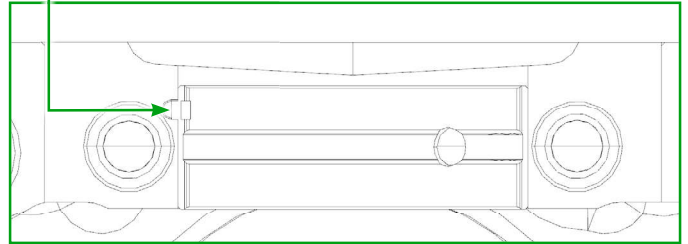
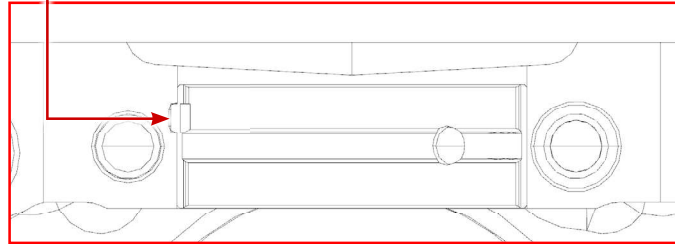
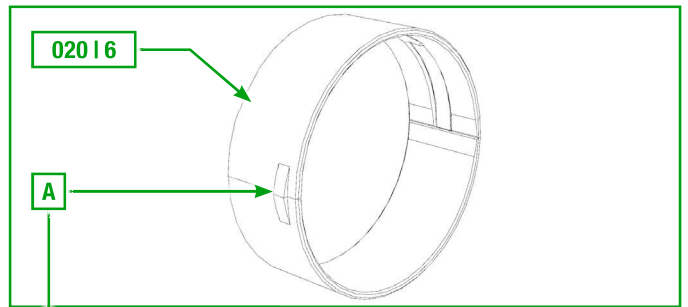
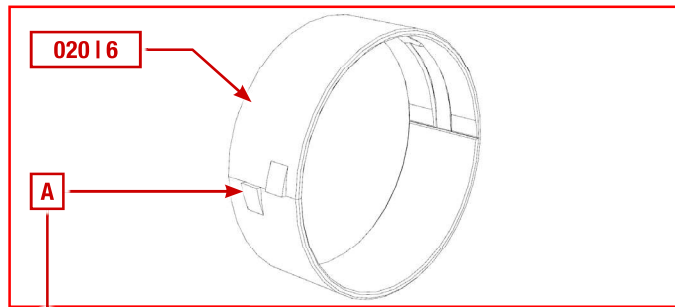

TAB.	Pos.	Code	Condition	Q.ty
020	1	ED0015109140-S	2 CYL	1
		ED0015112710-S	3 CYL	1
		ED0015112700-S	3 CYL	1
		ED0015112730-S	4 CYL	1
		ED0015112690-S	4 CYL	1
	2	ED0019701400-S		2
	6	ED0016111930-S	STD	
		ED0016111940-S	-0.25MM	3/4/5
		ED0016111950-S	-0.5	

TAB.	Pos.	Code	Condition	Q.ty
020	1	ED0015114940-S	2 CYL	1
		ED0015114960-S	3 CYL	1
		ED0015114980-S	3 CYL	1
		ED0015115000-S	4 CYL	1
		ED0015115020-S	4 CYL	1
	
	2		2 CYL	6
	10	ED0019705100-S	3 CYL	8
			4 CYL	10
	6	ED0016112600-S	STD	
ED0016112610-S		-0.25MM	3/4/5	
	ED0016112620-S	-0.5MM		

Condition

	+	-	D	<	E	I	N
IT	nuovo	eliminato	non più disponibile	montato fino a S/N	in esaurimento	intercambiabile	non intercambiabile
EN	New	Eliminated	No longer available	Assembled to S/N	Till stock lasts	Interchangeable	Not interchangeable
FR	Nouveau	Éliminé	Pas disponible	Monté jusqu'à S/N	En cours d'épuisement	Interchangeable	Pas interchangeable
ES	Nuevo	Eliminado	Ya no está disponible	Montado hasta S/N	Pocas existencias	Intercambiable	No intercambiable
DE	Neu	Entfallen	Nicht mehr erhältlich	Montiert bis Seriennr	Nur noch wenige Stücke vorrätig	Austauschbar	Nicht austauschbar

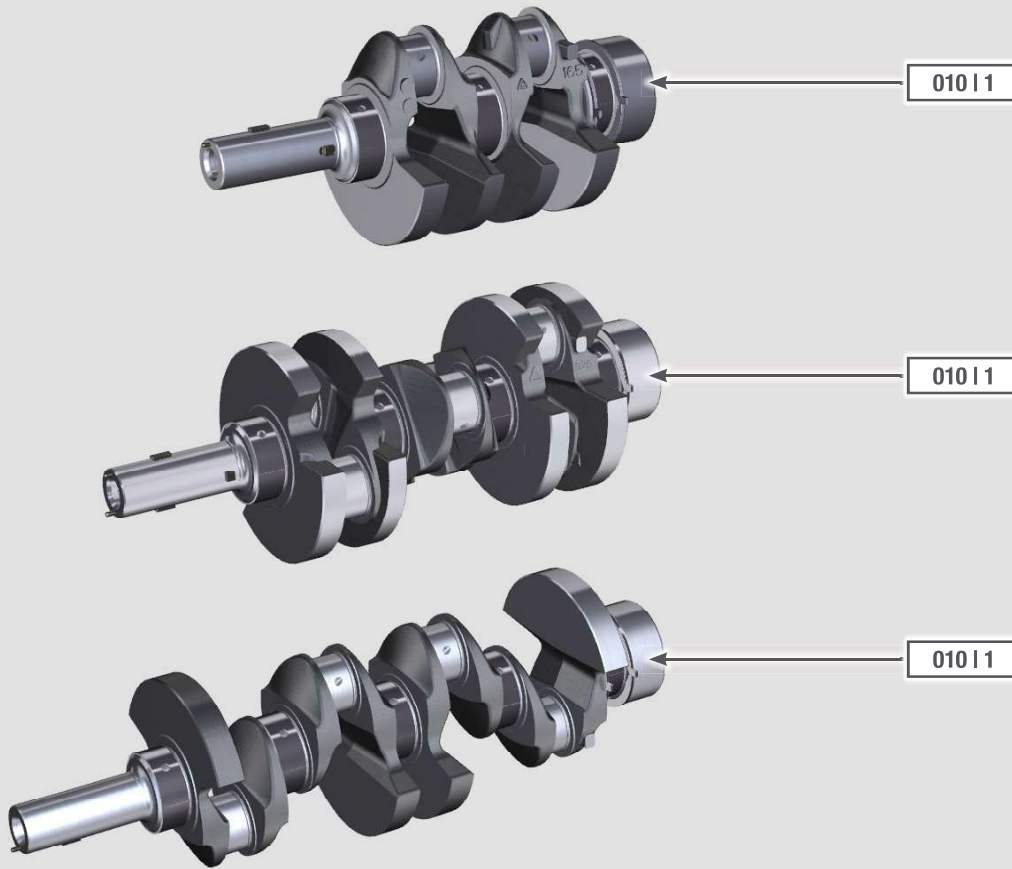

Prima		Before	Avant	Antes	Vorher	Dopo		After	Après	Después	Nachher
TAB.	Pos.	Code	Condition	Q.ty	TAB.	Pos.	Code	Condition	Q.ty		
010	1	ED0010511040-S	2 CYL	1	010	1	ED0010514920-S	2 CYL	1		
		ED0010511050-S	3 CYL				ED0010510040-S	3 CYL			
		ED0010509610-S	4 CYL				ED0010510330-S	4 CYL			

Condition							
	+	-	D	<	E	I	N
IT	nuovo	eliminato	non più disponibile	montato fino a S/N	in esaurimento	intercambiabile	non intercambiabile
EN	New	Eliminated	No longer available	Assembled to S/N	Till stock lasts	Interchangeable	Not interchangeable
FR	Nouveau	Éliminé	Pas disponible	Monté jusqu'à S/N	En cours d'épuisement	Interchangeable	Pas interchangeable
ES	Nuevo	Eliminado	Ya no está disponible	Montado hasta S/N	Pocas existencias	Intercambiable	No intercambiable
DE	Neu	Entfallen	Nicht mehr erhältlich	Montiert bis Seriennr	Nur noch wenige Stücke vorrätig	Austauschbar	Nicht austauschbar