

9.5-hp engines
(CH395)

TOP VIEW

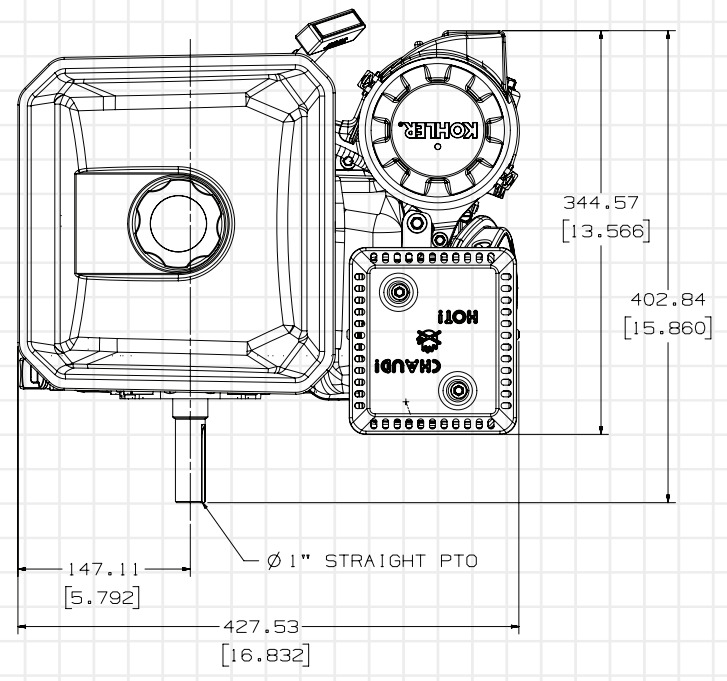

PTO VIEW

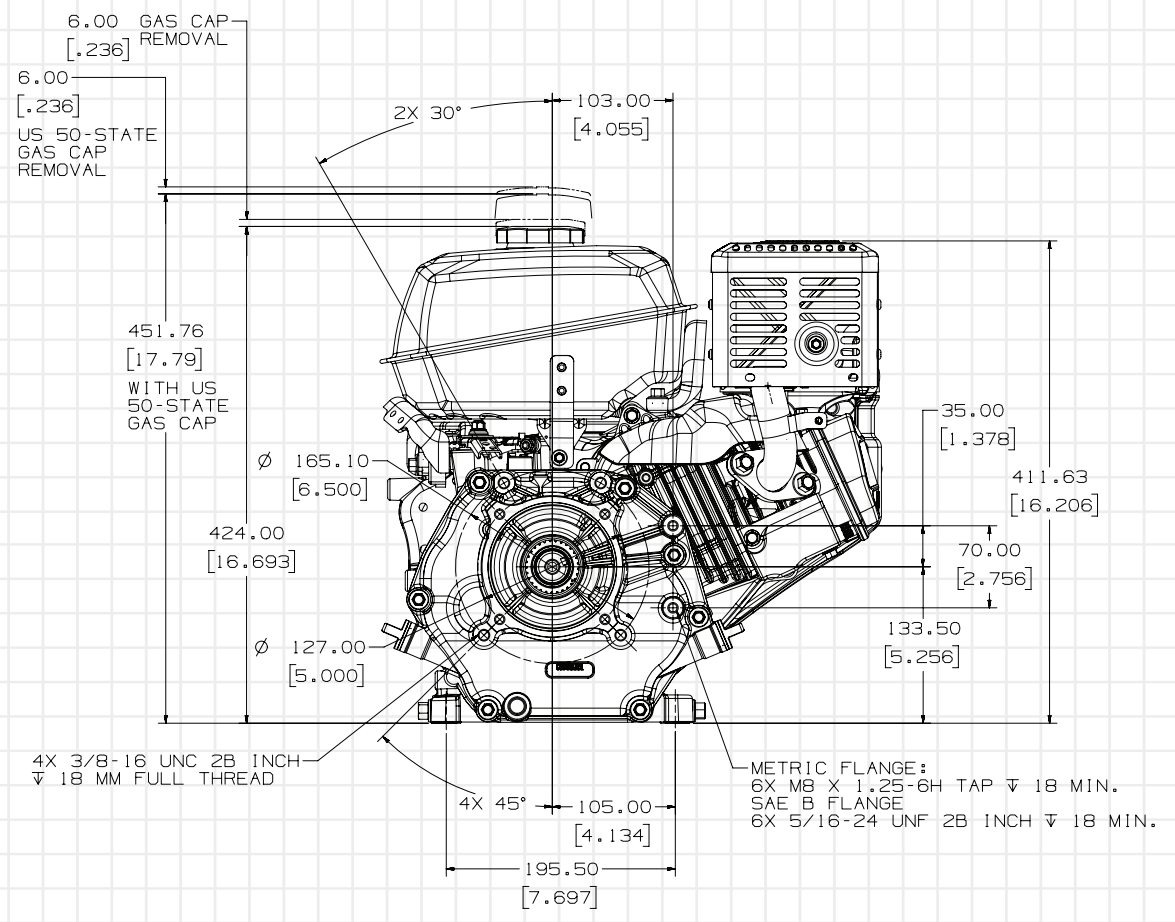

9.5-hp engines (CH395)

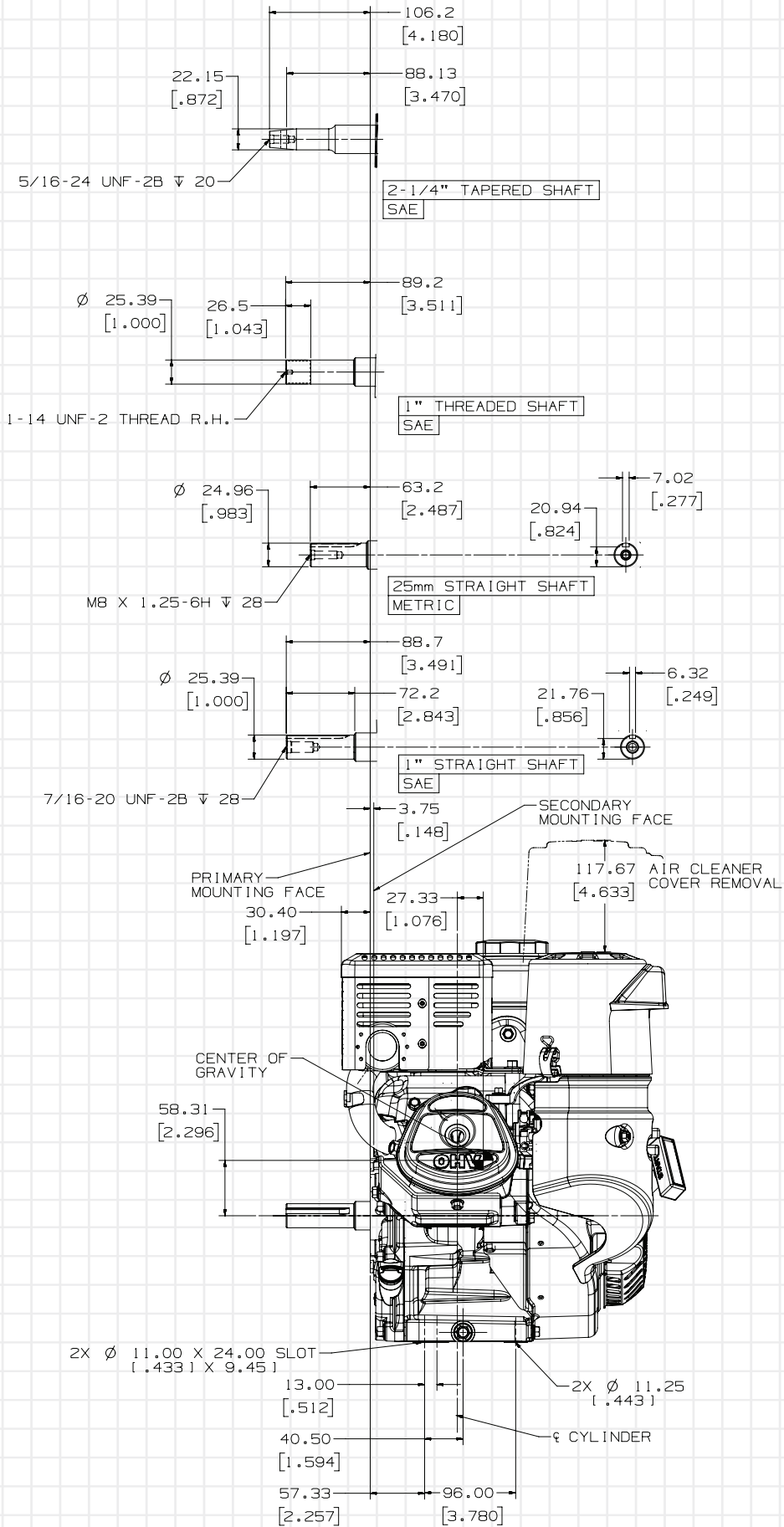

SHAFT VARIATIONS



VALVE COVER VIEW

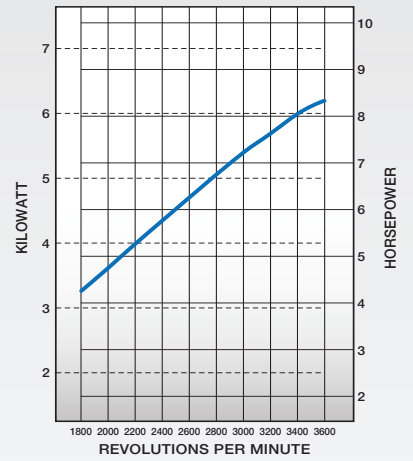

Net Power

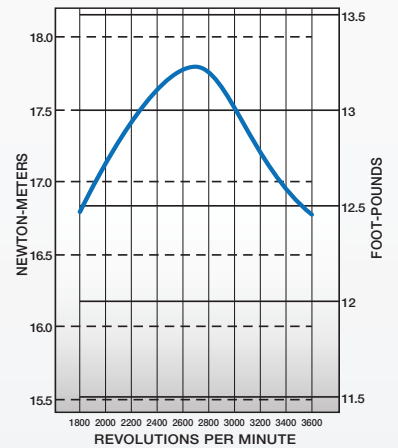

Net Torque