

Meccanismo monodisco

GG5 50553 311

Gunther	1°impianto	Codice	Ricambio	Applicazione	Codice

Disegno tecnico

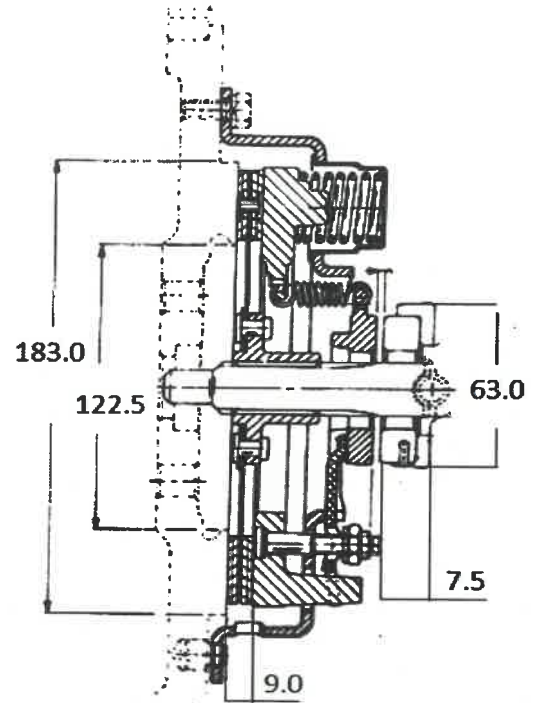
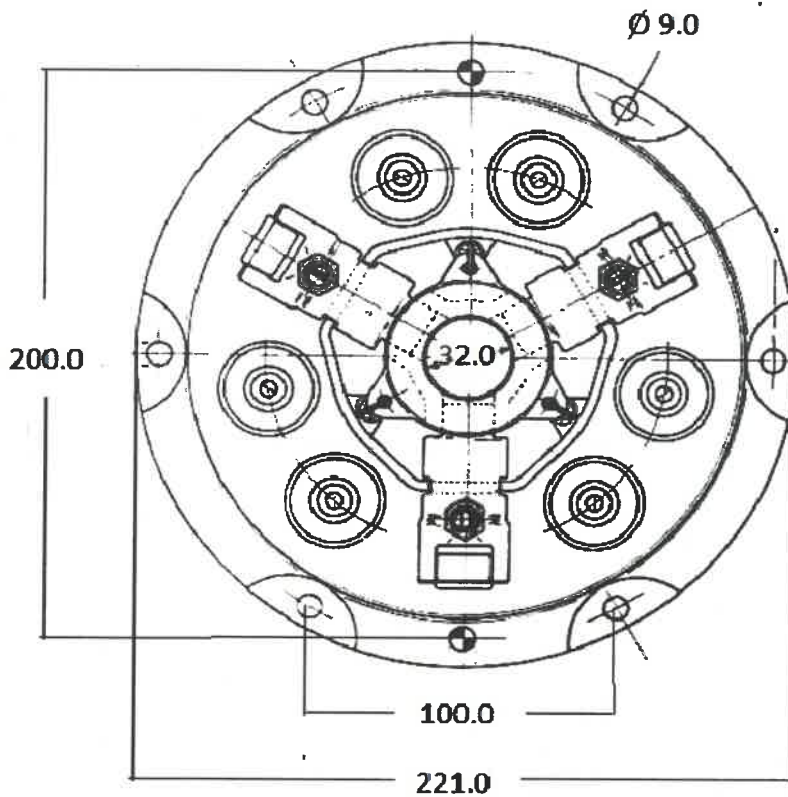

Caratteristiche

Diametro appoggio reggispinta	32,0	Max ingombro campana	221,0
Altezza campana		Diametro fori di centraggio	
Diametri interno piatto	122,5	Diametro fori di fissaggio	6x9,0
Diametro esterno piatto	183,0	Spessore piatto	9,0
Interasse max fori di fissaggio	200,0	Profondità avvitaento	
Interasse min. fori di fissaggio	100,0	Materiale	Lamiera
Altezza max base/diaframma		Peso Kg.	2,700

Note

Foto

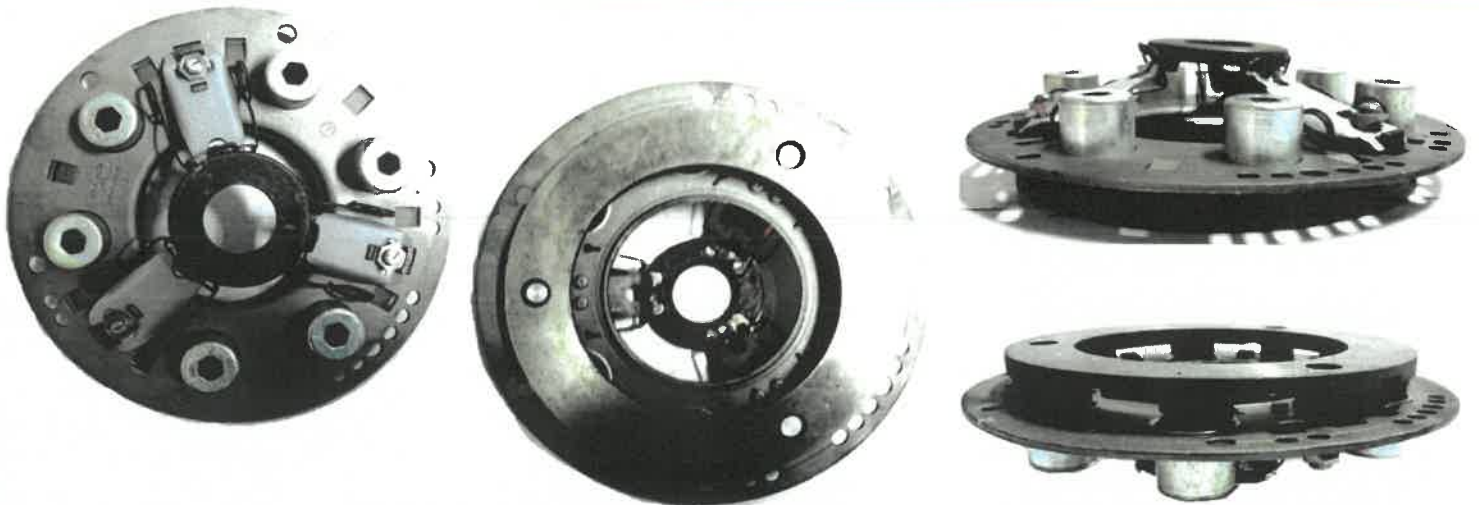

Disco frizione rigido

GG4 40219 008

Gunther	Marca	Codice	Ricambio	Codice	Adattabile
---------	-------	--------	----------	--------	------------

Disegno tecnico

Anello : 181x128x3,9

Tipo : B

Mozzo: 25x22xsp

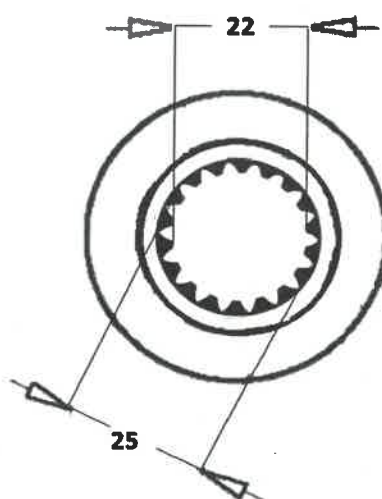
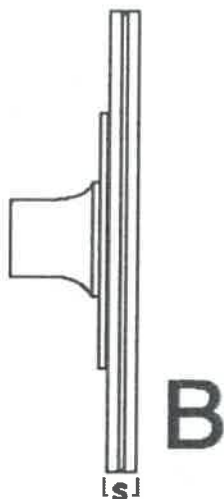
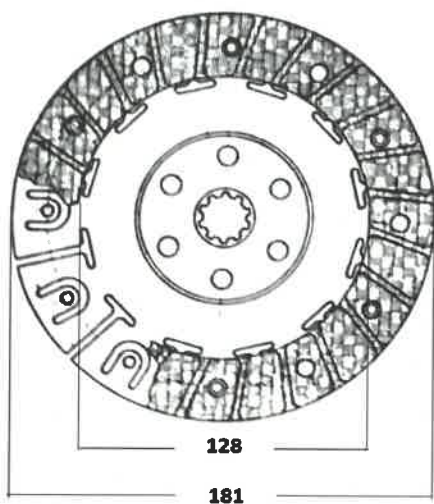

Spessore: 7,9

Cave: 14

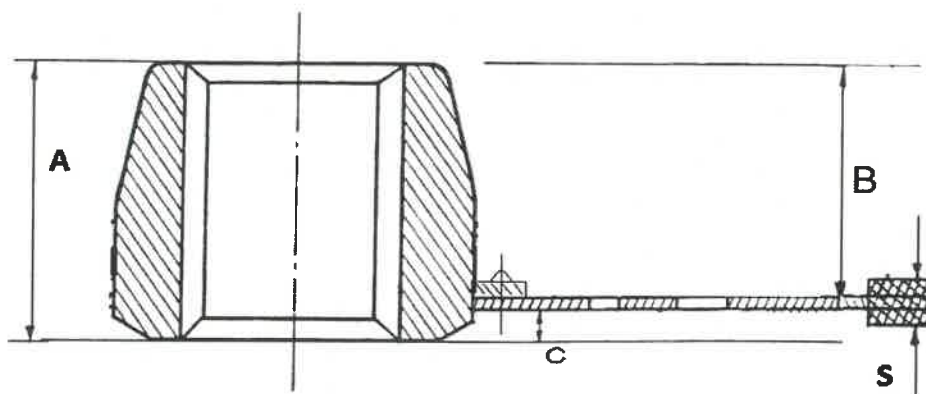

Caratteristiche in mm.

A=	27,3	C=				Kg.=	0,538
B=	22,3	S=	7,9				
Note:							

Foto:



GG6 62125 870

Disegno tecnico

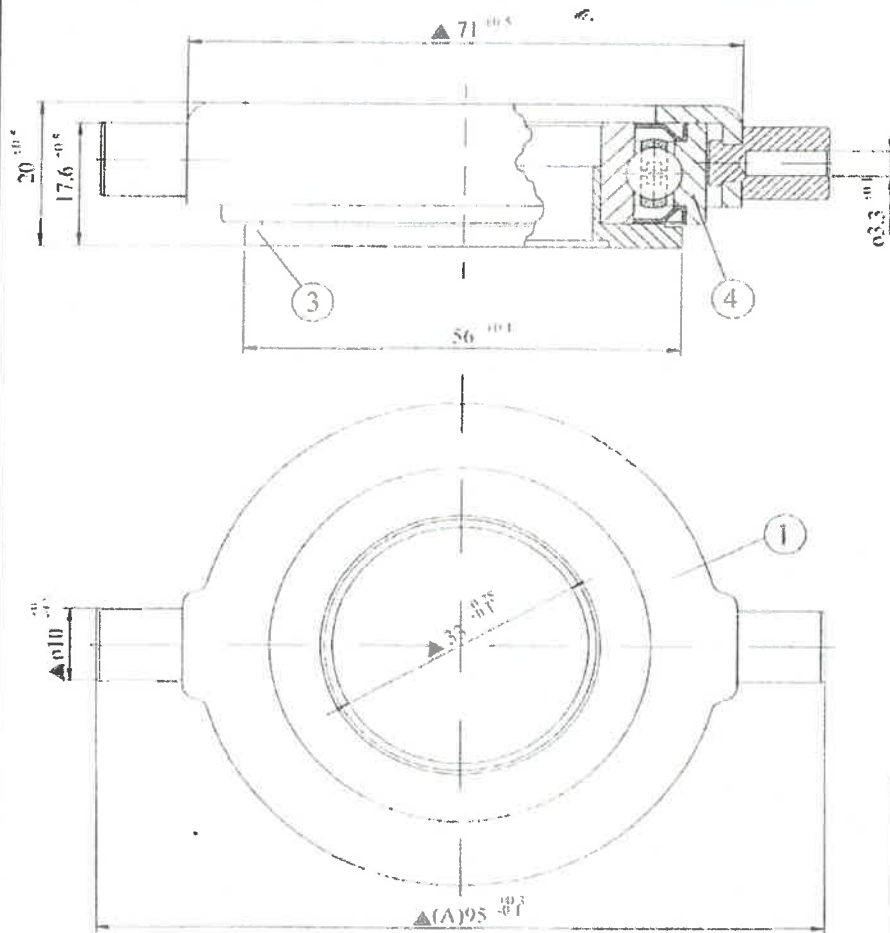

Caratteristiche

Tipo F&S

Peso: 275 gr.

Note

Foto: R111

